

KRINNER



Technical Description KRD 30

MACHINE SPECIFICATIONS

Special advantages

- Minor transport weight
- Small dimensions for ideal accessibility of difficult to access insertion positions
- Gasoline engine advantage in terms of emission regulations
- High torque, wide speed range
- Convenient transport and storage area
- Quick-change system on the rotating head and on the guide clamps
- Prepared for the Dokukit for the documentation according to DIN EN 12699
- Easy to maintain, rugged technology

Technical specifications

Width		900 mm
Length		2080 mm
Height	Transport	2080 mm
	Maximal	3500 mm
Weight		1100 kg
Engine	Performance	21,6 kW
	Speed	3600 U/min
	Fuel	Benzin
Driving speed		2,6 km/h
Torque		8000 Nm
Rotation speed of rotating head	1 Gear to 8000 Nm	16 U/min
	2 Gear to 4000 Nm	32 U/min
	3 Gear to 2000 Nm	64 U/min
Gun mount lifting		2,4 m
Insertion diameter		500 mm
Connecting flange	Floating position	200 daN
	Hydraulic downwards $200 + 2,5 \cdot \text{Druck}$ [bar]	400 daN (P80bar)
	Hydraulic upwards $- 200 + 5,7 \cdot \text{Druck}$ [bar]	600 daN (150bar)
Media connection on the rotary head		Water/ compressed air
Permitted terrain slope	Downward in direction of motion	10°
	Upward in direction of motion	15°
	Loading via ramps max	20°
	Transverse to the direction of motion	8°
	with trailer	8°
Surrounding temperature		-15° bis +40°
load capacity		200 kg
Trailer	vertical load	75 kg
	trailer load	750 kg

STANDARD MACHINE ACCESSORIES

Pos.	Articlenumber	Article
1	53301	Docu Kit
2	53334	Measuring unit
3	53346	Cable set docu-kit
4	53302	Retaining post documentation kit
5	53335	Toolholder
6	53321	Claw shoe
7	53322	KRD 30 standard support
8	53323	Trailer hitch
9	53356	6-edge universal adapter SW90 +350
10	53362	SW-attachment SW166
11	53372	SW-attachment
12	53304	Locking bar
13	53313	Tension bolt M16
14	53314	Tension bolt M24
16	53317	2 m probe arbor KRD 30
17	53324	Toggle guiding tongs
18	53326	Guide pliers NW50 cranked
19	53358	KRD 30 Replacement small parts

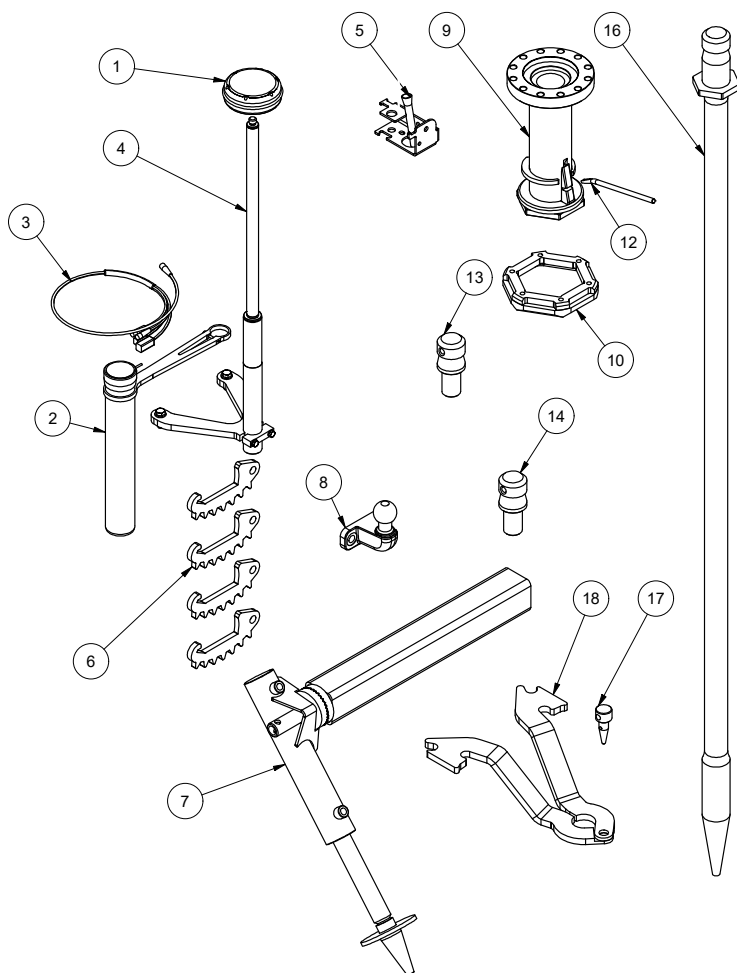

MASCHINE ACCESSOIRES

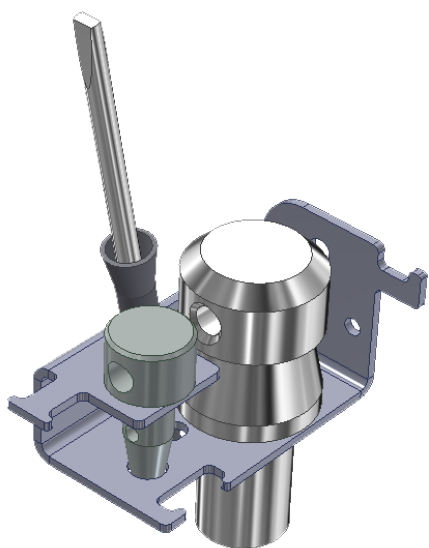

TOOL HOLDER (Art.nr.: 53335)

For holding the most important tools directly at the work position

6-KANT HEXAGON 90 (Art.nr.: 53356)

- Extends the motor flange by 350 mm, allowing it to be screwed in to 50 mm below site level
- Other adapters can be used via the quick-change system



LOCKING BAR (Art.nr.: 53304)

Used to loosen the quick-release system; also suitable for loosening tension bolts and adjusting the angle of the cross strut



PROBE ARBOR KRD 30 (D60)

- For pre-drilling foundation positions
- Available in nominal lengths of 1m (Art.nr.: 53316) and 2m (Art.nr.: 53317); the total length corresponds to the nominal length + 20cm

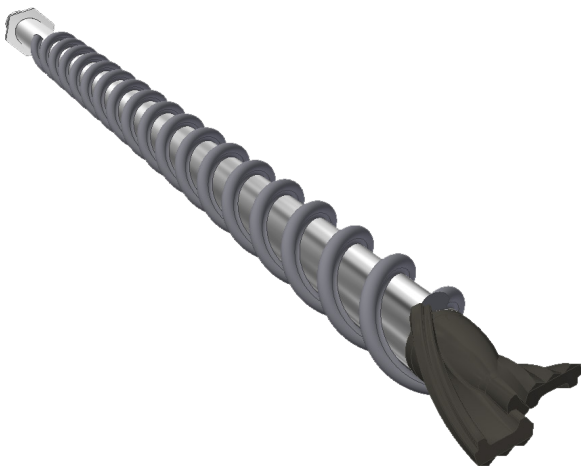

PRE-AUGER D100

Art.nr.: 53336

Extremely robust auger bit for pre-drilling in very dense soils



TENSION BOLT

- Tension bolt for secure fixing of foundations with central nut
- Available for M12 (Art.nr.: 53312)
M16 (Art.nr.: 53313)
M24 (Art.nr.: 53314)

MASCHINE ACCESSOIRES

ADAPTER SW

Art.nr.: 53362

- Reduces or extends the SW 160 standard adapter
- Available for SW120; SW180; SW200 (special sizes on request)



INPUT ADAPTER

Art.nr.: 53308

Adapter for screwing in the E89 series

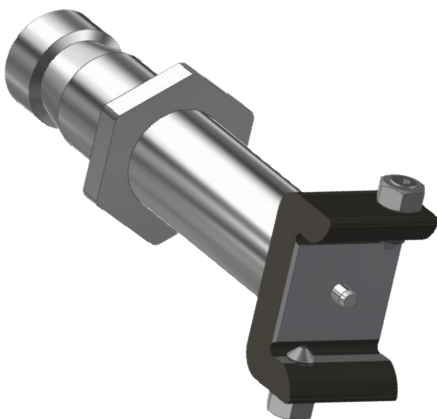

U-FIX ADAPTER

Art.nr.: 53337

Adapter for screwing in the U-Fix



G ADAPTER

- Adapter for screwing in KSF G types
- G76-3xM16 (Art.nr.:53339)
- G76-4xM16 (Art.nr.:53393)
- G89-4xM12 (Art.nr.:53338)
- G114-4xM16 (Art.nr.:53340)

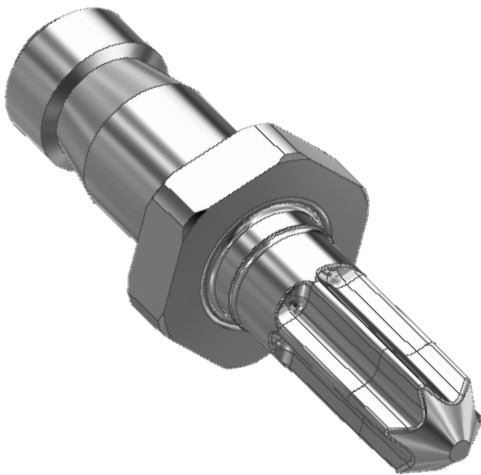

ADAPTER Q 60 Art.nr.: 53315

- Adapter for screwing in the KSF S 60 series

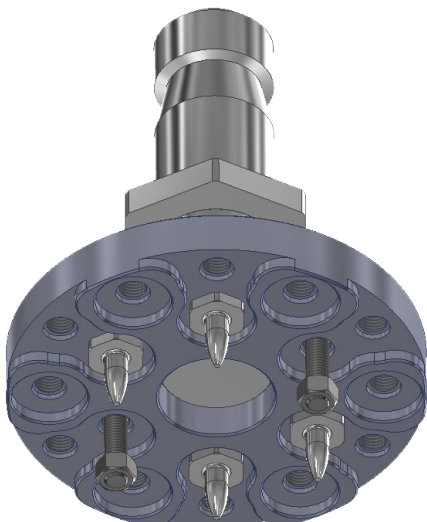

ADAPTER TK116; TK167; TK180 Art.nr.: 53309

- For the installation of flange foundations with pitch circles 116mm; 167mm; 180mm
- It is recommended to transmit the torque via 4 driving pins and 2 locking screws

MASCHINE ACCESSOIRES

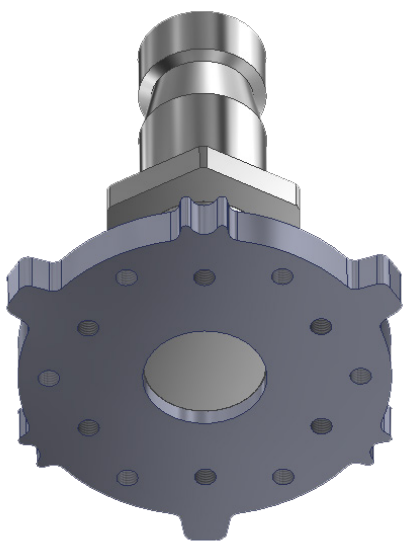

ADAPTER TK125; TK145; E140

Art.nr.: 53310

- For installation of the E140 series. In addition to adapting adapters via TK125 and TK145 M12
- The G-adapters of the KRD 55 can be used here, for example



ADAPTER 1/ 1/4"

Art.Nr.: 53341

- Adapter for core drill bits
- Connection thread 1 1/4" and hole for rinsing/cooling water



AUGER RECEIVING TAPS S4

Art.nr.: 53319

- Adapter for auger drill (S4)
- Diameter 65mm



DRILL DUST DEFLECTOR FOR ROCK HAMMER in three sizes

- Adapter for rock hammer with connection thread
- 53342 3"Hammer
- 53343 4"Hammer
- 53344 5"Hammer

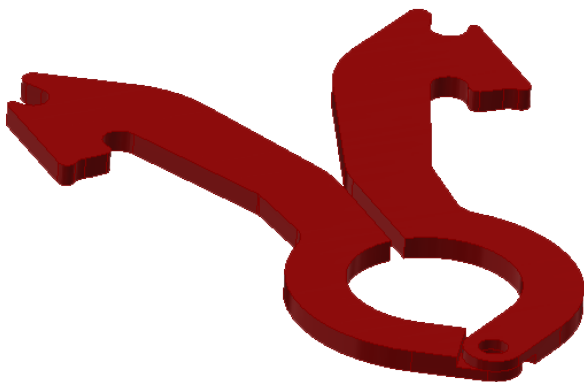

GUIDE PLIERS

- Guide pliers cranked NW50 (Art.nr.: 53326)
- Guide pliers NW114 (Art.nr.: 53330)
- Guide pliers with sleeve (+Version)
NW 85+ (D60+12) (Art.nr.:53327)
NW 97 (D76+10) (Art.nr.:53328)
NW 100 (Art.nr.:53350)
NW 111+ (D89+10)(Art.nr.:53329)
NW 114 (Art.nr.:53330)
NW 158+ (D114+20; 139+10) (Art.nr.:53331)
NW 240+ (Art.nr.:53325)

Special sizes on request

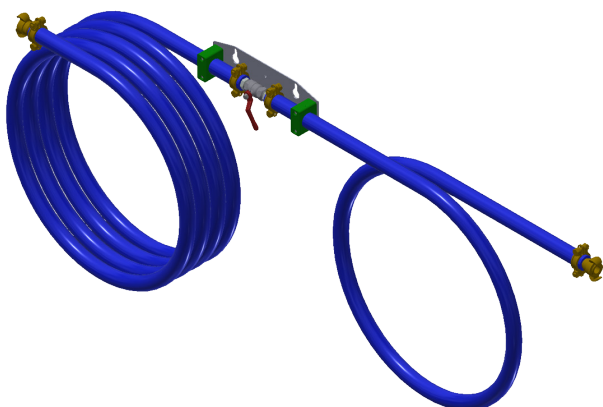

COMPRESSED AIR HOSE-KIT Art.nr.:53345

- For Installation on the operating panel, with ball valve for the compressed air supply

MACHINE ACCESSOIRES

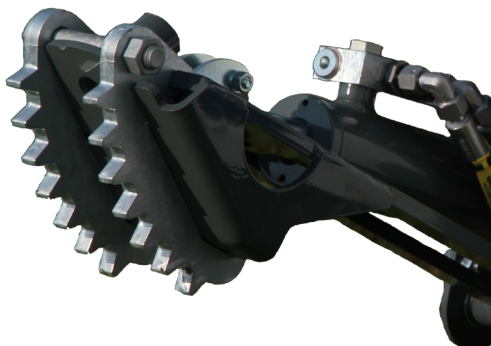

CLAW SHOE
Art.nr.:53321

- 4 pieces



KRD 30 STANDARD SUPPORT
Art.nr.:53322

- For stabilization and support for screwing-in process with high torque

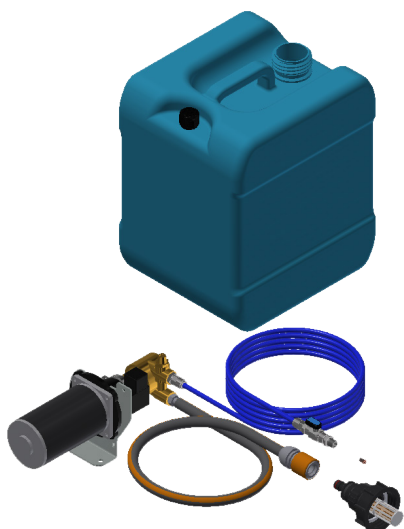

WATER PUMP KIT KRD 30
Art.nr.:53348

- For supplying water during core hole drilling or reducing dust formation during down-the-hole hammer drilling
- 20 liter canister with suction filter
- 12 volt pump 50l/h incl. wiring harness
- Atomizer nozzle for rock hammer drilling

PERIPHERAL / CUTTING SPEEDS

The peripheral speed is particularly important for the function and service life of the core bit. The recommended peripheral speeds are 2-5 m/s for impregnated crowns during wet drilling

CONTACT FORCES FOR DRILL BITS

The contact pressure of the drill bit on the material to be drilled is another important factor influencing the drilling result. The required contact pressure depends on the contact surface of the diamond segments on the material to be drilled.

Contact pressure for drilling in concrete: approx. 200-250 N/cm² (1 N corresponds to approx. 0.1 kp or approx. 0.1 kg weight force)

ATTENTION

If the pressure force is too high, this leads to increased segment wear and thus to a reduction in the service life of the drill bit. s

If the pressure force is too low, the cutting edges of the diamond will be polished, thus reducing the drilling progress.

KRINNER



Krinner Schraubfundamente GmbH

Passauer Straße 55

D-94342 Straßkirchen

Telefon: +49 9424 9401-80

www.krinner.io

service@krinner.com