

Technical Data sheet V 114x5

Basic Info

KSF V 114x5,0x 2000 PT HDG	KSF V 114x5,0x 1500 ET HDG	KSF V 114x5,0x 1500 EH HDG	KSF V 114x5,0x 860 E HDG	KSF V 114x5,0x 300 M24 HDG
Nominal length (mm)				
2000	1500	1500	860	300
Tube diameter (mm)				
114	114	114	114	114
Weight (kg)				
30	22	24	11	7
Steel grade (tube)				
S 235	S 235	S 235	S 235	S 235
Item number				
A0472	A0469	A0468	A0477	A0475



KSF V
114x5,0x300
M24 HDG



KSF V
114x5,0x2000 PT
HDG

Construction

- Flange: Sheet metal S 355
- Continuous welded helix
- Hot-dip galvanizing according to DIN EN ISO 1461
- Extra hard Hardox drive point
- Extra thick 5-mm-helix

Accessories



Screw Set KSF V 114 M24
Art.-Nr. A1379



KSF V
114x5,0x1500
ET HDG



KSF V
114x5,0x1500
EH HDG



KSF V
114x5,0x860 E
HDG



sustainable · durable · revolutionary

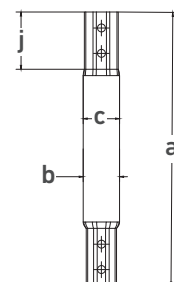
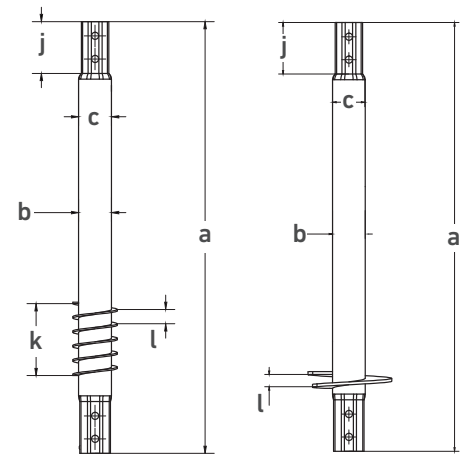
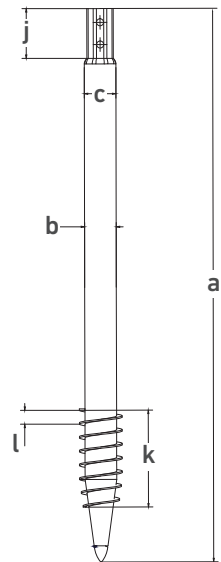
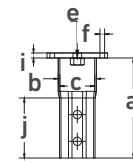
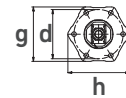

Technical Data

	KSF V 114x5,0x 2000 PT HDG	KSF V 114x5,0x 1500 ET HDG	KSF V 114x5,0x 1500 EH HDG	KSF V 114x5,0x 860 E HDG	KSF V 114x5,0x 300 M24 HDG
a	Length (mm)				
	2000	1500	1500	860	300
b	Outer diameter (mm)				
	114	114	114	114	114
c	Inner diameter (mm)				
	104	104	104	104	104
d	Pitch circle diameter (mm)				
	-	-	-	-	150
e	Central thread				
	-	-	-	-	M24
f	Pitch circle holes (mm)				
	-	-	-	-	6 x Ø 14
g	Flange wrench size (mm)				
	-	-	-	-	166
h	Flange outer diameter (mm)				
	-	-	-	-	182
i	Flange thickness (mm)				
	-	-	-	-	15
j	Octagon connection height (mm)				
	180	180	180	180	180
k	Thread length (mm)				
	450	250	-	-	-
l	Thread pitch (mm)				
	50	50	50	-	-